

Kids ONLY!

The Original **Big Wheel**

Big Wheel Junior

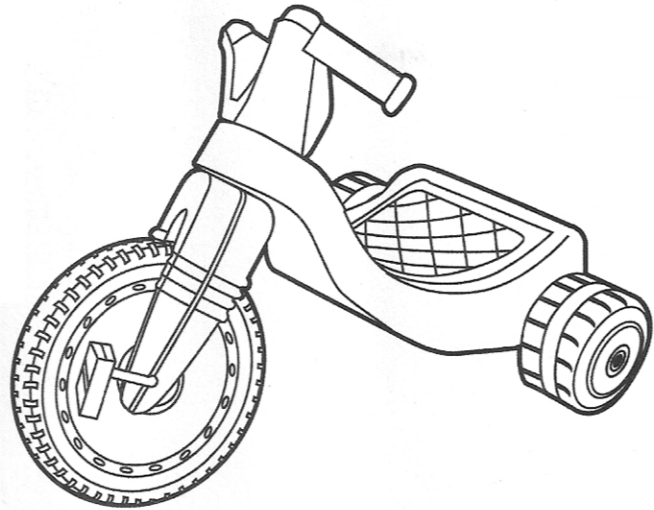

64732
 Ages: 18 months - 4 years
 Weight Limit: 35 lbs. (15.8 kg)

Tools required for assembly:
 Hammer, Phillips head screwdriver
 and small wood block (not included).
 Capnut tool (included).

Big Wheel Junior Parts List * Some extra parts included for convenience.

	Description	QTY
A	Capnut Tool (dispose when assembly is complete)	1
B	Axle Caps (for rear axle assembly)	2
C	Rear Axle	1
D	Rear Wheels	2
E	Body	1
F	Front Wheel	1
G	Front Wheel Crank Axle	1
H	Front Wheel Drive Inserts	2 sets
I	Fork	1
J	Screws (for fork assembly)	4
K	Foot Pedals	2
L	Handlebar	1
M	Handlebar Screw	1
N	Label Sheet	1

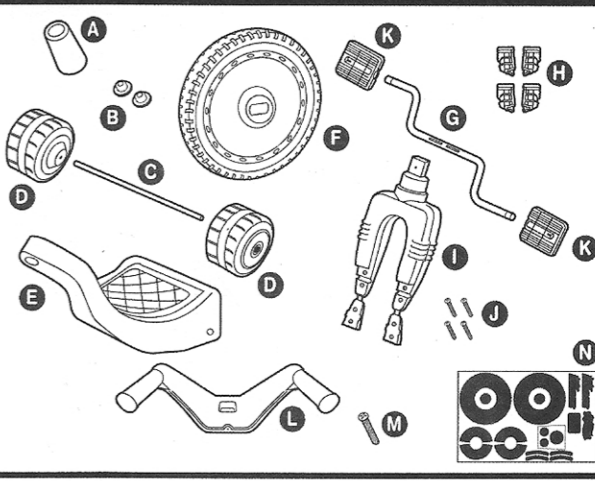

Note: Before assembly: Remove plastic caps from the Rear Axle and Front Wheel Crank Axle.

1 Using Capnut Tool (included), place Axle Cap onto one end of Rear Axle and hammer into place. **Note:** Axle Caps are NOT reusable if removed! Do not put second Axle Cap on until Step 3.

Non-scratch Surface

2 Slide one Rear Wheel, Body and second Rear Wheel onto Rear Axle. Pull up on Rear Axle to ensure proper fit.

Inner wheelwall faces body

Wood Block keeps Rear Axle Cap End flush with outer wheelwall

3 Slide second Rear Wheel onto Rear Axle, and attach second Axle Cap to secure Rear Axle assembly into place

Note: Wood Block is needed to ensure axle does not slide down. Wood Block should fit within the recess of the wheel.

Wood Block

4 Apply Label onto Front Wheel. Insert Front Wheel Crank Axle into Front Wheel.

5 Place one set of Front Wheel Drive Inserts (L & R) onto each side of Crank Axle, and insert into Front Wheel. Hold inserts in place and flip over to insert second set of Front Wheel Drive Inserts on opposite side of Front Wheel.

Insert Drive Inserts into Front Wheel

6 Attach Fork onto Front Wheel assembly, flip Fork Tips up and secure with screws (2 screws per side). Secure screws on opposite side of Fork.

Flip fork tips up before inserting screws

DO NOT OVER TIGHTEN SCREWS!

7 Slide Foot Pedal onto end of Front Wheel Crank Axle and push in to lock in place. Slightly tap Foot Pedal with Hammer to ensure TIGHT fit. Repeat for second Foot Pedal on other end.

8 Insert top end of Fork through neck hole on Body. Place the Handlebar as shown and press down firmly so that the Handlebar goes all the way down onto the top of the Fork. Hold in place and secure with the long Handlebar Screw.

DO NOT OVER TIGHTEN SCREW!

- WARNING: TO AVOID SERIOUS INJURY:**
- Continuous adult supervision required.
 - Never use near motor vehicles.
 - Never use near streets, swimming pools, hills, steps or sloped driveways.
 - Always wear shoes when using the tricycle.
 - Never allow more than 1 rider.
 - Conduct periodic inspection of hardware and proper maintenance of the unit.
 - Always wear a properly fitted helmet that complies with U.S. Consumer Safety Commission (CPSC) standards 16 CFR 1203. (Helmet not included).

- WARNING: ADULT ASSEMBLY REQUIRED:**
- Choking hazard to children under the age of 3 years - contains small parts prior to assembly.
 - Product contains small parts with potentially sharp points and edges.
 - Keep away from children prior to assembly.
 - Conforms to safety requirements of ASTM F963 and ANSI Z351.1

Label Placement

